



CAST RESIN TRANSFORMERS

DEFINITION

A dry-type transformer is one in which the magnetic circuit and the windings are not immersed in an insulating liquid, IEC 726.

SCOPE

This catalogue refers to cast-resin transformers with rated power levels between 100 and 2500 kVA, with higher voltage for the material, up to and including 36 kV. In addition, Electrical Power Systems manufactures transformers up to 5000 kVA in the 36 kV series.

GENERAL CHARACTERISTICS

The general details of our transformers are the follows: three-phase, continuous operation, indoor installation, degree of protection IP00, frequency 50 hz, AN cooling, thermal Class F.

MANUFACTURING STANDARDS

The transformers described in this catalogue are designed and tested in accordance to the European Union Harmonisations Documents HD 538 and HD 464 as well as IEC 726, IEC 76 standards.

However, and by request, they can be manufactured according to other national or international standards.



RATINGS

160 – 250 – 315 – 400 – 500 – 630 – 800 – 1000 – 1250 – 1600 – 2000 – 2500 – 3150 kVA

HIGH VOLTAGE

This material is designed for voltages of ≤ 36 . Specific figures are not given for this parameter because of the wide variety of voltages used. Transformers can be supplied on demand to run at two different primary voltages.

LOW VOLTAGE

The no load voltage is allocated at 400 V, though other voltages can be supplied on demand. When usage requires two voltages, transformers with two simultaneous voltages can be supplied. In this case no-load voltages are set to 400 and 231 V.

VECTOR GROUP

The connections normally used are as follows:

- For rated power levels of 160 kVA or less: Yzn11 or Dyn11
- For rated power levels 160 kVA: Dyn11.

INSULATION LEVELS

As per IEC 76, BS 171 and VDE 532 standards these are set in accordance with the highest voltage for the material, being the level immediately above the rated voltage.

Highest voltage for equipment Um (kV)	3,6	7,2	12	24	36
Withstand voltage AC (kV)	10	20	28	50	70
Basic insulation level LI (kV)	20	40	60	95	145

TEMPERATURE RISE

SNO-Energietechnik transformers are in the F insulation class, which, according to IEC 726, have a temperature rise of 100 K.

ADVANTAGES OF CAST RESIN TRANSFORMERS

Cast resin transformers have the following advantages:

Self-extinguishing

In case of fire outside the transformer but which affects it, it burns only with difficulty and with poor flame, which rapidly dies out when the source of fire ceases.

High Thermal inertia

Due to a greater mass than equivalent transformers in liquid, the time constant is much greater, so that there is better tolerances of overloads of short duration.

Compactness

The only components being the magnetic circuit, the windings and the fixing elements, the design is very compact, thus it is a robust assembly and vibration-proof. This makes transformers ideal for installation in mobile material.

Good resistances to short-circuits

As a result of the cast resin which surrounds the conductors as well as linking them strongly together, resistance to the electrodynamic forces generated in a short-circuit is very high. Again, as the density of current is lower than that the transformers with liquid, the maximum transient temperature reached in a short circuit is much lower than the limits specified in IEC 76.

Reduced maintenance

All that required is to clean dust off the surfaces, should it occur

Easy Installation

Protection against contacts is sufficient, since there is no need for a deposit to hold the liquid, nor brickwork installation

I- MAGNETIC CIRCUIT

This is made in oriented grain cold-rolled magnetic sheet with low losses, covered on both sides with a fine coat of inorganic insulation material. The cross-section is identical for legs and yokes with a step-ped shape. The number of steps used is according to the rated power.

The 45 °C type of joints used for the union between legs and yokes and the absence of bolts going through the yokes gives resulting low no load losses.

Both the legs and yokes are bound with special insulating heat-shrink tape, which makes for compact assembly and low vibration, reducing the noise level.

As a finish, a thick coat of compactant resin is applied to the entire exterior surface of the magnetic circuit, ensuring a permanent low noise level and preventing rust.



II- LOW VOLTAGE WINDING

Normally this winding is made with a bare-strip form conductor, although with low power levels a rectangular wire insulated with NOMEX is also used. In both cases insulating material pre-impregnated with epoxy resin is used between the layers which, in polymerizing, unites the conductors among themselves, producing a compact assembly with high resistance to the stress developed during a short-circuit.

This type of windings allows the insertion of one or more axial ducts, which facilitates the rapid dissipation of heat and the absence of hot points.

Finally, the finished coil is impregnated with epoxy resin which, once polymerized, gives it strong resistance against damp.

III- HIGH VOLTAGE WINDING

This winding is carried out with two different types of conductors: bare strip or enamelled wire. Strip windings are formed by several coils or disks made one after another in a continuous process. The turns, their insulations, the taps and the different positions are fully programmed, controlled, and directed through a computer intergrated iinto the automatic winding machine itself.

Enamelled wire conductor windings are also made in „wafers“ each one formed of several layers, between which insulating material is interleaved.

IV- CASTING PROCESS

The resin used by SNO-Energietechnik is of epoxy type with thermal class „F“, for a temperature rise of 100 K (maximum temperature of insulating system 155°C)

The casting system prepared for our manufacturing installation contemplates the use of four principal components:

- Epoxy resin
- Filler material
- Hardener
- Coloring

The casting process, the dosage of components and the different steps from moulding to polymerization.

The mixture of resin and hardener, with the filler material, is degassed under vacuum and at controlled temperature, before a final mixing and introduction into the moulds under vaccum.

The high technology of our casting station and the quality of the components used enables us to manufactures cast coils with practically total absence of partial discharges.

V- STRUCTURAL ELEMENTS

The structural fixing elements, both the tightening beams and the support and transport frames, are made of steel sections.

In order to elimnate vibration, layers of resilient material are interleaved between the magnetic circuit and the structural elements and also between the windings and supporting parts. This means that the expansion of the coils produced by increases of temperature is absorbed, as well as the vibration of the magentic sheet due to construction.

VI- CONNECTIONS

The High Voltage connection terminals are located at the front of the transformer and those for Low Voltage are the top.

The High Voltage terminals are of tinned copper with a hole of 14 mm diameter.

The Low Voltage terminals are always flag-type terminals with two or more holes 14 mm.

HIGHEST VOLTAGE FOR MATERIAL 12kV

Rated Power	160 – 3150 kVA
Rated Voltage HV	10 kV
Primary voltage tapplings	2 x +/-2,5%
Rated voltage LV	0,4 kV no load
Frequency	50 Hz
Schaltung	Dyn5 or Dyn11
Insulation level HV/LV	LI 60-AC28/- AC3 [kV]
Umgebungs-kategorie E2 Klimakategorie C2 Brand-kategorie F1	
Thermic class	F/F (HV/LV)
Degree of protection	IP00 (Indoor)
Winding material	HV:AL, LV:AL
Type of cooling	AN
Installation	< 1000 m a.s.l.
Ambient temperature	40 °C



Rated Power kVA	Rated HV Voltage kV	P ₀ (W) +15% Tol.	P _k (W) 120°C +15% Tol.	vcc (%) 120°C +/- 10% Tol	Weight (kg)	Length (mm)	Width (mm)	Hight (mm)	Distance between wheels (mm)	Noise level Lpa (dbA)	Preis (Euro)
160	10	480	2650	4	750	1120	650	1210	520	50	On request
250	10	670	3450	4	800	1240	650	1300	520	51	On request
315	10	750	4250	4	1215	1250	800	1340	670	52	On request
400	10	880	4850	4	1350	1360	800	1400	670	53	On request
400	10	820	5750	6	1350	1360	800	1400	670	53	On request
500	10	1000	6900	4	1480	1360	800	1460	670	54	On request
630	10	1050	8300	6	1640	1400	800	1570	670	55	On request
800	10	1330	9200	6	2050	1420	950	1720	670	56	On request
1000	10	1560	10150	6	2500	1540	950	1850	820	57	On request
1250	10	1870	12000	6	2950	1540	1000	1870	820	58	On request
1600	10	2200	14600	6	3450	1720	1280	2130	820	59	On request
2000	10	2800	17700	6	4200	1750	1280	2180	1070	60	On request
2500	10	3300	23000	6	4950	1900	1280	2210	1070	61	On request
3150	10	4500	25300	6	6000	2130	1300	2430	1070	63	On request

HIGHEST VOLTAGE FOR MATERIAL 24kV

Rated Power	160 – 3150 kVA
Rated Voltage HV	20 kV
Primary voltage tapplings	2 x +/-2,5%
Rated voltage LV	0,4 kV no load
Frequency	50 Hz
Schaltung	Dyn5 or Dyn11
Insulation level HV/LV	LI 95-AC50/- AC3 [kV]
Umgebungs-kategorie E2 Klimaklasse C2 Brandklasse F1	
Thermic class	F/F (HV/LV)
Degree of protection	IP00 (Indoor)
Winding material	HV:AL, LV:AL
Type of cooling	AN
Installation	< 1000 m a.s.l.
Ambient temperature	40 °C



Rated Power kVA	Rated HV Voltage kV	Po (W) +15% Tol.	Pk (W) 120°C +15% Tol.	vcc (%) 120°C +/- 10% Tol	Weight (kg)	Length (mm)	Width (mm)	Hight (mm)	Distance between wheels (mm)	Noise level Lpa (dbA)	Preis (Euro)
160	20	500	3000	6	750	1120	650	1210	520	52	On request
250	20	670	3800	6	800	1240	650	1300	520	53	On request
315	20	800	4600	6	1200	1250	800	1340	670	54	On request
400	20	940	5550	6	1350	1360	800	1400	670	55	On request
500	20	1100	6800	6	1480	1360	800	1460	670	56	On request
630	20	1270	7950	6	1640	1400	800	1570	670	57	On request
800	20	1500	9450	6	2050	1420	950	1720	670	59	On request
1000	20	1750	11050	6	2500	1540	950	1850	820	60	On request
1250	20	2000	13600	6	2950	1540	1000	1870	820	61	On request
1600	20	2400	16100	6	3450	1720	1280	2130	820	62	On request
2000	20	3000	19550	6	4200	1750	1280	2180	1070	63	On request
2500	20	3800	23000	6	4950	1900	1280	2210	1070	65	On request
3150	20	4800	26450	6	6200	2230	1280	2450	1070	65	On request

BASIC EQUIPMENT

Includes in all transformers supplied:

- Rating plate
- 4 lifting lugs
- 4 towing holes
- 4 two-way, 90° directional wheels

OPTIONAL ACCESSORIES

- Monitoring equipment with temperature indication and alarm and tripping contacts
- Forced cooling equipment
- Plug-in connections
- Device for tapping changeover
- Metal casing, protection IP31

VENTILATION

In order to avoid excessive and damaging heating, and for correct operation, it is essential to dissipate the thermal energy produced by the transformer during operation.

The natural circulation of air is directed from the lower part to the upper (chimney effect) and the dimensions of the openings are according to the losses to be dissipated and the temperature of the air entering and leaving the cell.

The lower opening must be located close to the transformer, as low as possible, while the upper one must have a cross-section 15% greater to compensate for the lesser density of the hot air.

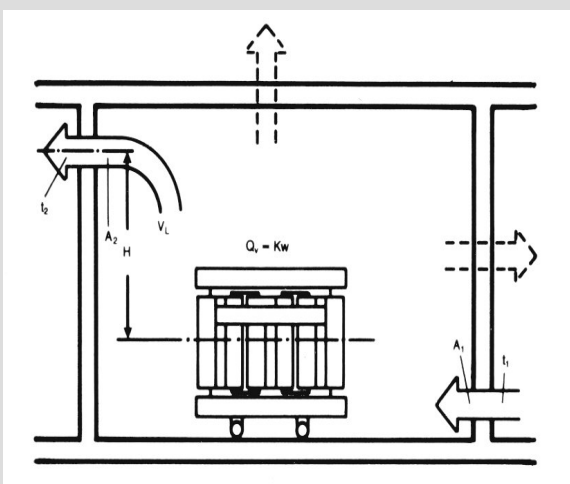

Calculation

The amount of air needed can be calculated according to the following formula:

$$V_i = P_t / 1,15 \times \Delta\theta \quad (\text{m}^3/\text{s})$$

The net surface of the lower grille is given by the formula:

$$A = 10,752 \times (P_t / \sqrt{H \times \Delta\theta^3}) \quad (\text{m}^2)$$

Where:

P_t = total losses to be eliminated in KW

$\Delta\theta$ = difference of temperature in °C

V_i = air intake in m³/s passing through the opening

H = distance in meters between the mid-point of the transformer and the mid point of the upper opening of the cell

A = net surface in m² (excluding the grille) of the lower opening

BUSBAR RANGE

Low Voltage Range:

- Lighting 25 – 40 A
- Distribution 63 – 160 A
- Distribution 160 – 1000 A
- Distribution 250 – 1600 A
- Transport 800 – 6300 A
- Flexibles 800 – 6300 A
- Trolley 50 – 300 A

Medium Voltage:

- Transport 800 – 5000 A (7.2 kV/24kV)



TRANSFORMER RANGE

- Oil immersed transformers with mineral or silicon oil and ratings from 25 kVA to 40.000 kVA
- Cast resin transformers with ratings from from 25 kVA to 15.000 kVA
- Transformers, autotransformers and reactors for special applications



Note

Possible changes in standards or materials can influence on electrical characteristics and overall dimensions shown in this catalogue. For this reason they may be considered final only after confirmation by SNO.

7 – SNO



Head Quarters
Essen - Germany

SNO-Energietechnik eine Marke der
Produkt Marketing OHG
Executive Board: Jürgen Maluchnik – Klaus Tabor
- Peter Wendt
Office adress: Schuirweg 74, D-45133 Essen
Ust-IdNr.: DE204037030 | Amtsgericht Essen
HRA 8865
Steuer - Nr.: 147/5995/0594
T | +49 (0)201 95 98 48 -0
F | +49 (0)201 95 98 48 -10
E | info@sno-energietechnik.de
WI www.sno-energietechnik.de

PM OHG Shareholder

Turnover 30 Mio €
58 employees



Transformer Plant
Turin - Italy

Turnover 9 Mio €
35 employees



Power Busbar Plant
Torino - Italy

Notices

SNO-Energietechnik

Eine Marke der Produkt Marketing oHG

Schuirweg 74
D-45133 Essen

www.sno-energietechnik.de

Firmenadresse:
Produkt Marketing oHG

Schuirweg 74
D-45133 Essen
T | +49 201 95 98 48 0
F | +49 201 95 98 48 10
E | info@sno-energietechnik.de

